

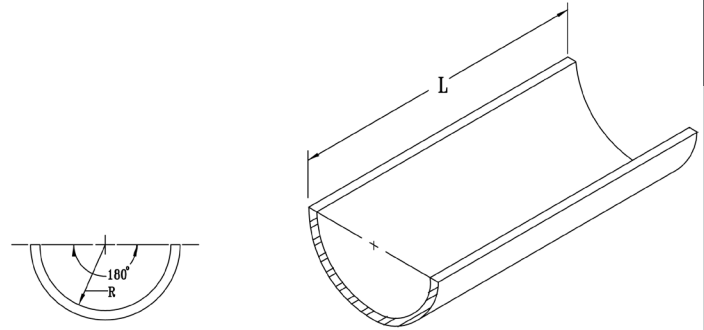

FIG. 183

INSULATION PROTECTION SHIELD

www.pipingtech.com/fig183

- MATERIAL:** Carbon steel
- FINISH:** Galvanized and black.
- SIZE RANGE:** For use with 1/2" thru 24" pipe with insulation thickness 1/2", 3/4", 1", 1 1/2" and 2".
- SERVICE:** Recommended for outside of foam or fiber glass insulation to preclude crushing of insulation without breaking the vapor barrier.
- APPROVALS:** Complies with Federal Specification WW-H-171E (Type 41) and Manufacturers Standardization Society SP-69 (Type 40).
- ORDERING:** Specify figure number, pipe size, description, insulation thickness and finish.



Shield Size Selection Table

PIPE SIZE	INSULATION THICKNESS (in.)				
	1/2	3/4	1	1 - 1/2	2
1/2	1A	1A	-	-	-
3/4	1A	1A	2A	4A	6A
1	1A	2A	3A	5A	7A
1 1/4	2A	3A	3A	6A	7A
1 1/2	2A	3A	4A	6A	7A
2	3A	4A	5A	7A	8A
2 1/2	4A	5A	6A	7A	8A
3	5A	6A	7A	8A	9A
3 1/2	-	-	8A	9A	10A
4	-	-	8A	9A	10A
5	-	-	9B	10B	11B
6	-	-	10B	11B	12B
8	-	-	-	13C	14C
10	-	-	14C	15C	16C
12	-	-	16C	17C	18C
14	-	-	17C	18C	19C
16	-	-	19C	20C	21C
18	-	-	21C	22C	23C
20	-	-	23C	24C	25C
24	-	-	26C	27C	28C

SHIELD SIZE	STOCK SIZE (GAGE)	APPROX. WEIGHT EACH	SHIELD DIMENSION	
			LENGTH L	RADIUS R
X1A	18	0.54	12	0.95
1A	18	0.69	12	1.19
2A	18	0.84	12	1.44
3A	18	0.99	12	1.75
4A	18	1.10	12	2.00
5A	18	1.30	12	2.25
6A	18	1.40	12	2.50
7A	18	1.60	12	2.78
8A	16	1.90	12	3.32
9A	16	2.70	12	3.82
10A	16	3.10	12	4.32
9B	16	4.00	18	3.82
10B	16	4.60	18	4.32
11B	16	5.10	18	4.82
12B	16	5.60	18	5.38
13C	14	10.20	24	5.88
14C	14	11.10	24	6.38
15C	14	11.90	24	7.00
16C	14	12.70	24	7.50
17C	14	13.60	24	8.00
18C	14	14.50	24	8.50
19C	12	21.20	24	9.00
20C	12	22.40	24	9.50
21C	12	23.60	24	10.00
22C	12	24.80	24	10.50
23C	12	25.90	24	11.00
24C	12	27.10	24	11.50
25C	12	28.30	24	12.00
26C	12	31.00	24	13.00
27C	12	31.80	24	13.50
28C	12	33.00	24	14.00

SCOMPONENTS05.XLS-09/02/11