



FIG. 46

ADJUSTABLE PIPE SADDLE SUPPORT

www.pipingtech.com/fig46

MATERIAL: Carbon steel saddle, locknut nipple, and special cast iron reducer, assembled. Base is not included - supplied as extra.

SERVICE: Stanchion type support where vertical adjustment is required.

INSTALLATION: Adjustment is obtained by turning the locknut nipple, the lower end of the nipple, and coupling during adjustment.

ORDERING: Specify figure number, pipe size, description and finish.

*Max load varies based on overall height

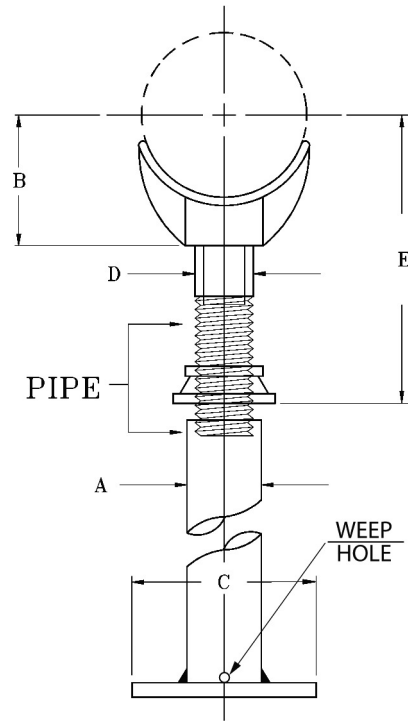

SUPPORT ASSEMBLY COMPONENTS

PIPE SIZE	APPROX. WEIGHT (lb. per 100)		A	B	C	D	E		MAX LOAD*
	COMPLETE	SADDLE ONLY					MIN.	MAX.	
2 1/2	900	480	2 1/2	3 1/2	9	1 1/2	8	13	2,000
3	920	500	2 1/2	3 3/4	9	1 1/2	8 1/4	13 1/4	2,000
3 1/2	940	520	2 1/2	4	9	1 1/2	8 1/2	13 1/2	2,000
4	1,500	760	3	4 1/4	9	2 1/2	9 1/4	14	3,800
5	1,665	925	3	4 7/8	9	2 1/2	10	14 3/4	3,800
6	1,765	1,025	3	5 1/2	9	2 1/2	10 1/2	15 1/4	3,800
8	2,020	1,280	3	6 7/8	9	2 1/2	11 3/4	16 1/2	3,800
10	2,515	1,775	3	8 1/2	9	2 1/2	13 1/2	18 1/4	3,800
12	2,900	2,160	3	9 15/16	9	2 1/2	15	19 3/4	3,800
14	4,920	3,800	4	10 15/16	11	3	16 1/4	20 3/4	5,300
16	5,320	4,200	4	12 3/8	11	3	17 3/4	22 1/4	5,300
18	7,080	5,100	6	13 7/8	13 1/2	3 1/2	19 1/2	24	6,700
20	10,480	8,500	6	15 3/8	13 1/2	3 1/2	21	25 1/2	6,700
24	13,000	11,000	6	17 15/16	13 1/2	4	23 3/4	28 1/4	7,300
30	17,000	15,000	6	21 5/16	13 1/2	4	27	31 1/2	7,300
32	18,100	16,100	6	22 1/2	13 1/2	4	28 1/4	32 3/4	7,300
36	24,900	22,900	6	24 1/2	13 1/2	4	30 1/4	34 3/4	7,300

SCOMPONENTS05.XLS-04/22/17