



## FIG. PTP 100-D

## CONSTANT

ENGINEERED PIPE SUPPORTS

[www.pipingtech.com/ptp100-d](http://www.pipingtech.com/ptp100-d)

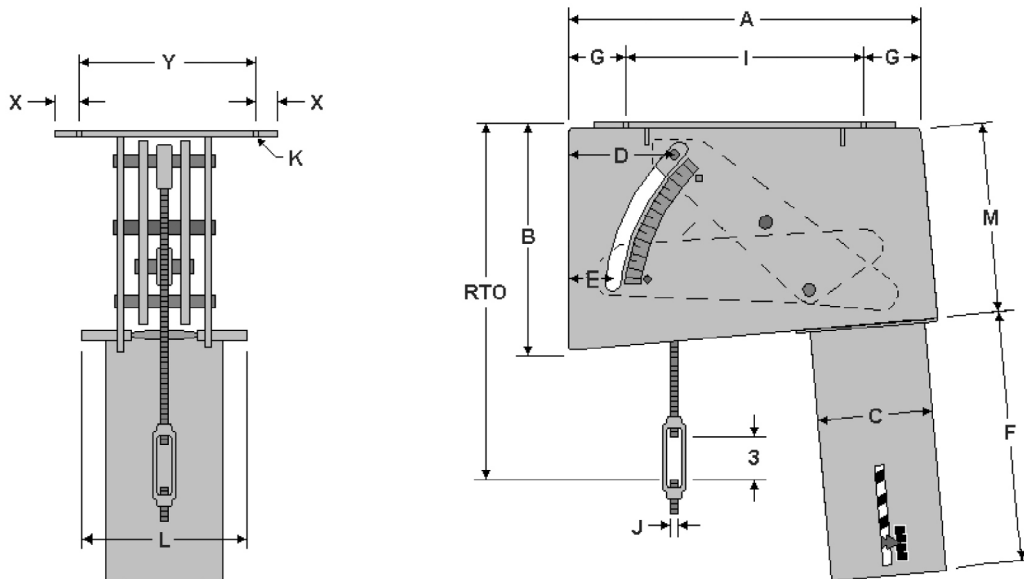

\* Drawing shown for down travel

Figure PTP 100-D is a vertical constant with a top attachment which is bolted directly to the bottom of the steel as shown above.

**ORDERING:** Specify figure number, size, type, load, actual travel, total travel and direction of travel. For load and travel not in the tables, please call for dimensions.

**IMPORTANT NOTES:** All dimensions are in inches unless otherwise noted.

- RTO - Rod take out for down travel
- D - J-Rod position for down travel
- E - J-Rod position for up travel
- F - Maximum length for the load range
- WT - Maximum weight for the load range

### J-Rod and Lug Selection

LOAD (lb.)	0	766	1492	2403	3869	5664	9122	13355	17776	23660	28628	38104	46105
	765	1491	2402	3868	5663	9121	13354	17775	23659	28627	38103	46104	60000
J-ROD	1/2	5/8	3/4	1	1 1/4	1 1/2	1 3/4	2	2 1/4	2 1/2	2 3/4	3	3 1/4
K-HOLE	9/16	3/4	3/4	3/4	3/4	7/8	7/8	1 3/8	1 3/8	1 5/8	1 5/8	1 5/8	1 5/8
X	3/4	7/8	7/8	1 1/8	1 1/8	1 3/8	1 3/8	1 5/8	1 5/8	2	2	2	2
Y	5 5/8	8	8	10 3/4	10 3/4	12 5/8	12 5/8	14 5/8	14 5/8	15	15	15	15

### Total Travel 1 1/2 to 4 inches

LOAD RANGE (lb.)	J-ROD	RTO*	A	B	C	D	E	F	G	I	L	M	WT (lb.)
44 - 243	1/2	14 1/16	16 3/8	9 11/16	6 5/8	3 3/4	2	12	1 7/8	12 5/8	7 5/8	8	65
244 - 1018	1/2	14 1/16	17 3/8	10 1/8	8 5/8	3 3/4	2	15	2 3/8	12 5/8	11 5/8	8 3/8	105
	5/8	14 1/16											
1019 - 3516	5/8	14 1/4	17 3/8	11 1/8	8 5/8	3 3/4	2	22	2 3/8	12 5/8	11 5/8	9 1/4	225
	3/4	14 1/4											
	1	16 1/4											

\*Rod Take Out (RTO) is for down travel [ Add 4 inches for up travel ]



## FIG. PTP 100-D

## CONSTANT

[www.pipingtech.com/ptp100-d](http://www.pipingtech.com/ptp100-d)

### Total Travel 1 1/2 to 4 inches

LOAD RANGE (lb.)	J-ROD	RTO*	A	B	C	D	E	F	G	I	L	M	WT (lb.)
3517 - 7538	1	16 13/16	20 3/8	12 1/2	8 5/8	4 5/16	2 9/16	33	3 1/2	13 3/8	11 5/8	10 1/8	395
	1 1/4	17 13/16											
	1 1/2	18 1/16											
7539 - 16159	1 1/2	19 1/16	23 9/16	15 3/8	12 3/4	5 9/16	3 7/8	44	4 3/8	14 13/16	18 3/8	12 5/8	1,045
	1 3/4	20 9/16											
	2	24 9/16											
16160 - 31490	2	26 3/4	24 1/4	18 15/16	12 3/4	6 3/4	5	58	6 1/2	11 1/4	18 3/8	16 1/16	1,700
	2 1/4	28 3/4											
	2 1/2	28 3/4											
	2 3/4	30 3/4											

\*Rod Take Out (RTO) is for down travel [ Add 4 inches for up travel ]

### Total Travel 4 1/2 to 6 inches

LOAD RANGE (lb.)	J-ROD	RTO*	A	B	C	D	E	F	G	I	L	M	WT (lb.)
34 - 183	1/2	14 1/16	18 11/16	12	6 5/8	4 1/2	1 7/8	12	2	14 11/16	7 5/8	10 1/16	75
184 - 765	1/2	14 1/16	19 11/16	12 1/2	8 5/8	4 1/2	1 7/8	15	2 3/4	14 3/16	11 5/8	10 1/2	115
766 - 2402	5/8	14 1/4	19 11/16	13 5/8	8 5/8	4 1/2	1 7/8	22	2	15 11/16	11 5/8	11 1/2	230
	3/4	14 1/4											
2403 - 5663	1	16 13/16	22 13/16	15	8 5/8	5 1/4	2 5/8	33	3 1/4	16 5/16	11 5/8	12 7/16	400
	1 1/4	17 13/16											
5664 - 12140	1 1/2	18 5/8	25 1/4	17 5/16	12 3/4	5 3/4	3 1/8	44	3 3/4	17 3/4	18 3/8	14 7/16	1,035
	1 3/4	20 1/8											
12141 - 23659	1 3/4	22 5/16	26 5/8	20 7/8	12 3/4	7 1/4	4 5/8	58	6 5/8	13 3/8	18 3/8	17 7/8	1,640
	2	26 5/16											
	2 1/4	28 5/16											

\*Rod Take Out (RTO) is for down travel [ Add 6 inches for up travel ]

### Total Travel 6 1/2 to 8 inches

LOAD RANGE (lb.)	J-ROD	RTO*	A	B	C	D	E	F	G	I	L	M	WT (lb.)
25 - 151	1/2	18 1/16	21 1/4	14 1/2	6 5/8	5 9/16	2	12	2 1/4	16 3/4	7 5/8	12 5/16	90
152 - 632	1/2	18 1/16	22 1/4	15	8 5/8	5 9/16	2	15	2 1/4	17 3/4	11 5/8	12 3/4	130
633 - 1985	1/2	18 1/4	22 1/4	16	8 5/8	5 9/16	2	22	2 1/4	17 3/4	11 5/8	13 5/8	255
	5/8	18 1/4											
	3/4	18 1/4											
1986 - 4680	3/4	18 13/16	25 1/8	16 7/8	8 5/8	6 1/16	2 1/2	33	3	19 1/8	11 5/8	14 1/8	420
	1	20 13/16											
	1 1/4	21 13/16											
4681 - 10033	1 1/4	22 3/8	27 13/16	19 15/16	12 3/4	6 13/16	3 1/4	44	3 1/2	20 13/16	18 3/8	16 13/16	1,090
	1 1/2	22 5/8											
	1 3/4	24 1/8											
10034 - 19552	1 3/4	25 7/8	30 3/16	23 7/16	12 3/4	9 5/16	5 3/4	58	4 3/4	20 11/16	18 3/8	20 1/8	1,700
	2	29 7/8											
	2 1/4	31 7/8											

\*Rod Take Out (RTO) is for down travel [ Add 8 inches for up travel ]

CONSTANTS\_100.XLS-04/22/17



## FIG. PTP 100-D

## CONSTANT

ENGINEERED PIPE SUPPORTS

[www.pipingtech.com/ptp100-d](http://www.pipingtech.com/ptp100-d)

### Total Travel 8 1/2 to 10 inches

LOAD RANGE (lb.)	J-ROD	RTO*	A	B	C	D	E	F	G	I	L	M	WT (lb.)
21 - 125	1/2	20 1/16	23 3/4	16 5/8	6 5/8	6 5/8	2 1/8	12	2 3/4	18 1/4	7 5/8	14 1/4	100
126 - 522	1/2	20 1/16	24 13/16	16 7/8	8 5/8	6 5/8	2 1/8	15	2 3/4	19 5/16	11 5/8	14 3/8	145
523 - 1640	1/2	20 1/4	24 3/4	18	8 5/8	6 5/8	2 1/8	22	2 3/4	19 1/4	11 5/8	15 3/8	280
	5/8	20 1/4											
	3/4	20 1/4											
1641 - 3868	3/4	20 3/8	27 1/4	18 3/4	8 5/8	6 7/8	2 3/8	33	3 1/2	20 1/4	11 5/8	15 3/4	430
	1	22 3/8											
3869 - 8292	1 1/4	23 15/16	29 7/8	21 3/4	12 3/4	7 3/8	2 7/8	44	3 1/2	22 7/8	18 3/8	18 3/8	1,115
	1 1/2	24 3/16											
8293 - 16159	1 1/2	25 1/16	31 1/16	23 15/16	12 3/4	8 5/8	4 1/8	58	5 1/4	20 9/16	18 3/8	20 1/2	1,685
	1 3/4	26 9/16											
	2	30 9/16											

\*Rod Take Out (RTO) is for down travel [ Add 10 inches for up travel ]

### Total Travel 10 1/2 to 12 inches

LOAD RANGE (lb.)	J-ROD	RTO*	A	B	C	D	E	F	G	I	L	M	WT (lb.)
17 - 103	1/2	22 1/16	26 3/8	19	6 5/8	7 5/8	2 1/4	12	3 1/4	19 7/8	7 5/8	16 3/8	120
104 - 432	1/2	22	27 3/8	19 1/2	8 5/8	7 5/8	2 1/4	15	3 1/4	20 7/8	11 5/8	16 3/4	160
433 - 1491	1/2	22 3/16	27 3/8	20 1/8	8 5/8	7 5/8	2 1/4	22	3 1/8	21 1/8	11 5/8	17 5/16	300
	5/8	22 3/16											
1492 - 3197	3/4	22 3/8	29 3/4	21	8 5/8	7 5/8	2 1/4	33	3 3/8	23	11 5/8	17 13/16	475
	1	24 3/8											
3198 - 6853	1	24 15/16	32 1/2	23 7/8	12 3/4	8 3/8	3	44	3 5/8	25 1/4	18 3/8	20 5/16	1,170
	1 1/4	25 15/16											
	1 1/2	26 3/16											
6854 - 13354	1 1/2	27 1/16	33 5/8	26 1/8	12 3/4	9 5/8	4 1/4	58	3 1/4	29 1/8	18 3/8	22 1/2	1,710
	1 3/4	28 9/16											

\*Rod Take Out (RTO) is for down travel [ Add 12 inches for up travel ]

### Total Travel 12 1/2 to 14 inches

LOAD RANGE (lb.)	J-ROD	RTO*	A	B	C	D	E	F	G	I	L	M	WT (lb.)
17 - 94	1/2	24 1/16	28 5/8	20 15/16	6 5/8	8 1/2	2 1/8	12	3 3/4	21 1/8	7 5/8	18 1/8	135
95 - 392	1/2	24 1/16	29 11/16	21 1/2	8 5/8	8 1/2	2 1/8	15	3 3/4	22 3/16	11 5/8	18 5/8	180
393 - 1232	1/2	24 3/16	29 11/16	22 11/16	8 5/8	8 1/2	2 1/8	22	3 3/4	22 3/16	11 5/8	19 5/8	330
	5/8	24 3/16											
1233 - 2906	5/8	24 3/8	32 5/16	23	8 5/8	8 3/4	2 3/8	33	3 3/4	24 13/16	11 5/8	19 9/16	510
	3/4	24 3/8											
	1	26 3/8											
2907 - 6230	1	26 15/16	34 3/4	26 1/16	12 3/4	9 1/4	2 7/8	44	4 1/4	26 1/4	18 3/8	22 5/16	1,225
	1 1/4	27 15/16											
	1 1/2	28 3/16											
6231 - 12140	1 1/2	28 5/8	35 1/2	27 13/16	12 3/4	10	3 5/8	58	3 3/4	28	18 3/8	24	1,755
	1 3/4	30 1/8											

\*Rod Take Out (RTO) is for down travel [ Add 14 inches for up travel ]

CONSTANTS\_100.XLS-04/22/17