

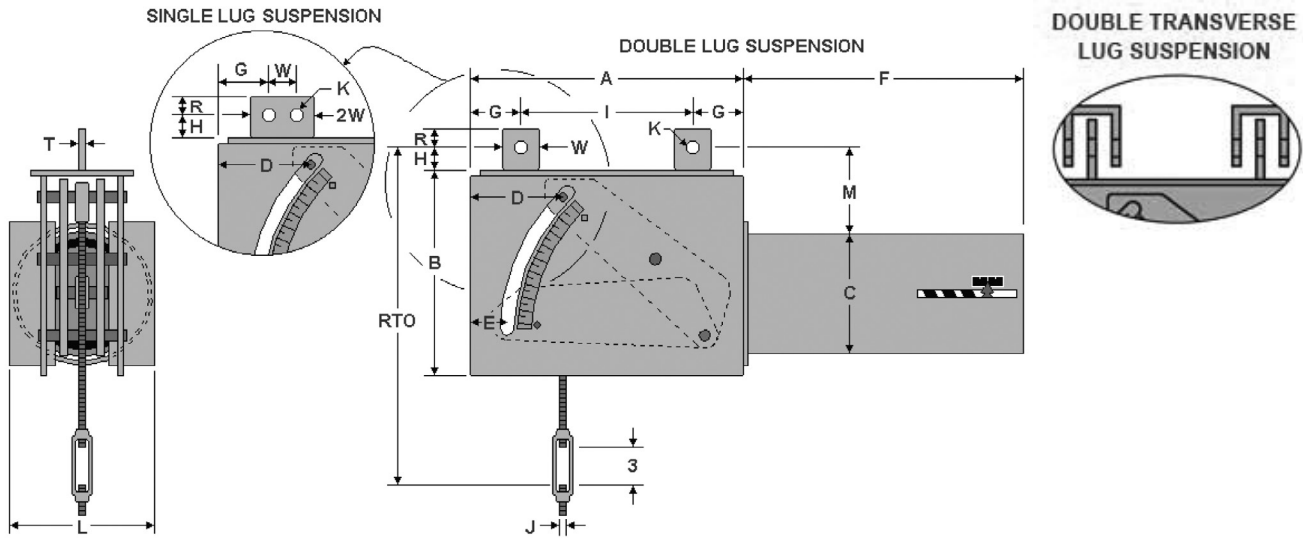

FIG. PTP 200-B

CONSTANT

ENGINEERED PIPE SUPPORTS

www.pipingtech.com/ptp200-b



* Drawing shown for down travel

Figure PTP 200-B is a horizontal constant suspended from a beam. It can be furnished with single lug suspension or double lug suspension as shown above.

ORDERING: Specify figure number, size, type, load, actual travel, total travel and direction of travel. For load and travel not in the tables, please call for dimensions.

IMPORTANT NOTES: All dimensions are in inches unless otherwise noted.

- RTO - Rod take out for down travel
- D - J-Rod position for down travel
- E - J-Rod position for up travel
- F - Maximum length for the load range
- M - Maximum height for the load range
- WT - Maximum weight for the load range

J-Rod and Lug Selection

LOAD (lb.)	0	766	1492	2403	3869	5664	9122	13355	17776	23660	28628	38104	46105
	765	1491	2402	3868	5663	9121	13354	17775	23659	28627	38103	46104	60000
J-ROD	1/2	5/8	3/4	1	1 1/4	1 1/2	1 3/4	2	2 1/4	2 1/2	2 3/4	3	3 1/4
K-HOLE	11/16	13/16	15/16	1 1/4	1 1/2	1 3/4	2	2 3/8	2 5/8	2 7/8	3 1/8	3 3/8	3 5/8
H	1 1/2	1 1/2	1 1/2	2	3	3	3	4	4 1/2	4 1/2	4 1/2	5	5
R	1 1/4	1 1/4	1 1/4	1 1/2	2	2 1/2	2 1/2	3	3	4	4	4	4 1/2
T	1/4	1/4	3/8	1/2	5/8	3/4	3/4	3/4	3/4	1	1	1	1
W	2 1/2	2 1/2	2 1/2	3	4	5	5	6	6	8	8	8	9

Total Travel 1 1/2 to 4 inches

LOAD RANGE (lb.)	J-ROD	RTO*	A	B	C	D	E	F	G	I	L	M	WT (lb.)
44 - 243	1/2	16 1/4	12 1/2	8 3/4	6 5/8	3 7/8	2 5/16	12	1 7/8	8 3/4	7 5/8	2 3/4	60
244 - 1018	1/2	17 1/4	13 1/2	11	8 5/8	4 3/8	2 13/16	15	2 3/8	8 3/4	11 5/8	2 3/4	105
	5/8	17 1/4											
1019 - 3516	5/8	17 3/8	14	11 1/8	8 5/8	4 3/8	2 13/16	22	2 3/8	9 1/4	11 5/8	2 7/8	215
	3/4	17 3/8											
	1	19 7/8											

*Rod Take Out (RTO) is for down travel [Add 4 inches for up travel]

CONSTANTS_200.XLS-04/22/17



FIG. PTP 200-B

CONSTANT

www.pipingtech.com/ptp200-b

Total Travel 1 1/2 to 4 inches

LOAD RANGE (lb.)	J-ROD	RTO*	A	B	C	D	E	F	G	I	L	M	WT (lb.)
3517 - 7538	1	22 7/16	15 3/4	13 1/4	8 5/8	5 7/8	4 1/4	33	3 1/2	8 3/4	11 5/8	3 1/2	380
	1 1/4	24 7/16											
	1 1/2	24 11/16											
7539 - 16159	1 1/2	26 3/4	19 3/4	16 7/8	12 3/4	7 5/8	6 1/16	44	4 3/8	11	18 3/8	4 1/2	1,035
	1 3/4	28 1/4											
	2	33 1/4											
16160 - 31490	2	35 1/4	23 3/4	19 7/8	12 3/4	10 3/8	8 13/16	58	6 1/2	10 3/4	18 3/8	7 1/2	1,705
	2 1/4	37 3/4											
	2 1/2	37 3/4											
	2 3/4	39 3/4											

*Rod Take Out (RTO) is for down travel [Add 4 inches for up travel]

CONSTANTS_200.XLS-04/22/17

Total Travel 4 1/2 to 6 inches

LOAD RANGE (lb.)	J-ROD	RTO*	A	B	C	D	E	F	G	I	L	M	WT (lb.)
34 - 183	1/2	15 9/16	15 1/4	10 1/4	6 5/8	4 3/8	2	12	2	11 1/4	7 5/8	4 3/16	65
184 - 765	1/2	16 1/16	16 3/4	11 3/4	8 5/8	5 1/8	2 3/4	15	2 3/4	11 1/4	11 5/8	3 11/16	110
766 - 2402	5/8	15 11/16	16 1/2	11 3/8	8 5/8	4 3/8	2	22	2	12 1/2	11 5/8	3 5/16	215
	3/4	15 11/16											
2403 - 5663	1	20 3/8	18	13 1/4	8 5/8	5 7/8	3 1/2	33	3 1/4	11 1/2	11 5/8	3 1/2	365
	1 1/4	22 3/8											
5664 - 12140	1 1/2	24 11/16	21 3/4	16 7/8	12 3/4	7 3/8	5	44	3 3/4	14 1/4	18 3/8	4 1/2	1,015
	1 3/4	26 3/16											
12141 - 23659	1 3/4	29	26	20 5/8	12 3/4	10 5/16	7 15/16	58	6 5/8	12 3/4	18 3/8	7 5/16	1,640
	2	34											
	2 1/4	36 1/2											

*Rod Take Out (RTO) is for down travel [Add 6 inches for up travel]

CONSTANTS_200.XLS-04/22/17

Total Travel 6 1/2 to 8 inches

LOAD RANGE (lb.)	J-ROD	RTO*	A	B	C	D	E	F	G	I	L	M	WT (lb.)
25 - 151	1/2	15 9/16	18	12 1/4	6 5/8	5 1/8	1 7/8	12	2 1/4	13 1/2	7 5/8	6 1/8	75
152 - 632	1/2	15 9/16	18 1/2	13 1/4	8 5/8	5 1/8	1 7/8	15	2 1/4	14	11 5/8	5 1/8	120
633 - 1985	1/2	15 3/4	19 1/2	13 3/8	8 5/8	5 1/8	1 7/8	22	2 1/4	15	11 5/8	5 5/16	235
	5/8	15 3/4											
	3/4	15 3/4											
1986 - 4680	3/4	16 5/16	20 3/4	14	8 5/8	5 7/8	2 5/8	33	3	14 3/4	11 5/8	3 7/16	390
	1	18 13/16											
	1 1/4	20 13/16											
4681 - 10033	1 1/4	22 3/8	23 3/4	16 7/8	12 3/4	7 1/8	3 7/8	44	3 1/2	16 3/4	18 3/8	4 1/2	1,030
	1 1/2	22 5/8											
	1 3/4	24 1/8											
10034 - 19552	1 3/4	24 7/8	26 3/4	18 5/8	12 3/4	8 7/8	5 5/8	58	4 3/4	17 1/4	18 3/8	5 1/4	1,610
	2	29 7/8											
	2 1/4	32 3/8											

*Rod Take Out (RTO) is for down travel [Add 8 inches for up travel]

CONSTANTS_200.XLS-04/22/17



FIG. PTP 200-B

CONSTANT

ENGINEERED PIPE SUPPORTS

www.pipingtech.com/ptp200-b

Total Travel 8 1/2 to 10 inches

LOAD RANGE (lb.)	J-ROD	RTO*	A	B	C	D	E	F	G	I	L	M	WT (lb.)
21 - 125	1/2	17 9/16	21	14 1/4	6 5/8	6 1/16	2 1/16	12	2 3/4	15 1/2	7 5/8	8 1/8	90
126 - 522	1/2	17 9/16	21 1/2	15 1/4	8 5/8	6 1/16	2 1/16	15	2 3/4	16	11 5/8	7 1/8	130
523 - 1640	1/2	17 3/4	22 1/2	15 3/8	8 5/8	6 1/16	2 1/16	22	2 3/4	17	11 5/8	7 5/16	255
	5/8	17 3/4											
	3/4	17 3/4											
1641 - 3868	3/4	18 5/16	23 3/4	16	8 5/8	6 13/16	2 13/16	33	3 1/2	16 3/4	11 5/8	5 1/2	405
	1	20 13/16											
3869 - 8292	1 1/4	23 3/8	26 1/4	17 7/8	12 3/4	7 9/16	3 9/16	44	3 1/2	19 1/4	18 3/8	5 1/2	1,050
	1 1/2	23 5/8											
8293 - 16159	1 1/2	25 3/8	30	20 3/8	12 3/4	9 13/16	5 13/16	58	5 1/4	19 1/2	18 3/8	7 1/4	1,650
	1 3/4	26 7/8											
	2	31 7/8											

*Rod Take Out (RTO) is for down travel [Add 10 inches for up travel]

CONSTANTS_200.XLS-04/22/17

Total Travel 10 1/2 to 12 inches

LOAD RANGE (lb.)	J-ROD	RTO*	A	B	C	D	E	F	G	I	L	M	WT (lb.)
17 - 103	1/2	19 9/16	24 1/2	16 1/4	6 5/8	7	2 1/8	12	3 1/4	18	7 5/8	10 1/8	105
104 - 432	1/2	19 9/16	24 1/2	17 1/4	8 5/8	6 15/16	2 1/16	15	3 1/4	18	11 5/8	9 1/8	150
433 - 1491	1/2	19 11/16	25	17 3/8	8 5/8	6 13/16	2	22	3 1/8	18 3/4	11 5/8	9 1/4	280
	5/8	19 11/16											
1492 - 3197	3/4	19 7/8	25 3/4	17 1/4	8 5/8	7 1/16	2 1/4	33	3 3/8	19	11 5/8	7 1/16	420
	1	22 3/8											
3198 - 6853	1	22 15/16	28 1/2	19 3/8	12 3/4	7 9/16	2 3/4	44	3 5/8	21 1/4	18 3/8	6 1/16	1,090
	1 1/4	24 15/16											
	1 1/2	25 3/16											
6854 - 13354	1 1/2	25 5/8	30	20 7/8	12 3/4	8 1/16	3 1/4	58	3 1/4	23 1/2	18 3/8	7 1/2	1,610
	1 3/4	27 1/8											

*Rod Take Out (RTO) is for down travel [Add 12 inches for up travel]

CONSTANTS_200.XLS-04/22/17

Total Travel 12 1/2 to 14 inches

LOAD RANGE (lb.)	J-ROD	RTO*	A	B	C	D	E	F	G	I	L	M	WT (lb.)
17 - 94	1/2	21 9/16	27	18 1/4	6 5/8	7 13/16	2 1/8	12	3 3/4	19 1/2	7 5/8	12 3/16	120
95 - 392	1/2	21 9/16	27 1/2	19 1/4	8 5/8	7 7/8	2 1/4	15	3 3/4	20	11 5/8	11 3/16	165
393 - 1232	1/2	21 11/16	28 1/4	19 3/8	8 5/8	7 13/16	2 1/8	22	3 3/4	20 3/4	11 5/8	11 5/16	310
	5/8	21 11/16											
1233 - 2906	5/8	21 7/8	28 3/4	19 1/2	8 5/8	7 13/16	2 1/8	33	3 3/4	21 1/4	11 5/8	9 1/16	470
	3/4	21 7/8											
	1	24 3/8											
2907 - 6230	1	24 15/16	31 3/4	21 5/8	12 3/4	8 9/16	2 7/8	44	4 1/4	23 1/4	18 3/8	8 1/16	1,155
	1 1/4	26 15/16											
	1 1/2	27 3/16											
6231 - 12140	1 1/2	27 5/8	31	21 1/8	12 3/4	9 1/16	3 3/8	58	3 3/4	23 1/2	18 3/8	9 1/2	1,615
	1 3/4	29 1/8											

*Rod Take Out (RTO) is for down travel [Add 14 inches for up travel]

CONSTANTS_200.XLS-04/22/17