



## FIG. 42 & 43

## YOKE U-BOLT

**MATERIAL:** Yoke, load bolt and load distribution strap is chrome molybdenum steel. U-Bolt is stainless steel.

**SERVICE:** Recommended for suspension of high temperature piping requiring 4" to 6" of insulation.

**MAX. TEMP.:** 1100 °F

**ORDERING:**  
**Fig. 42** - Specify figure number, pipe size and description.  
**Fig. 43** - Specify figure number, nominal pipe size, and description.

**NOTE:** Strap provided on Fig. 43 only.

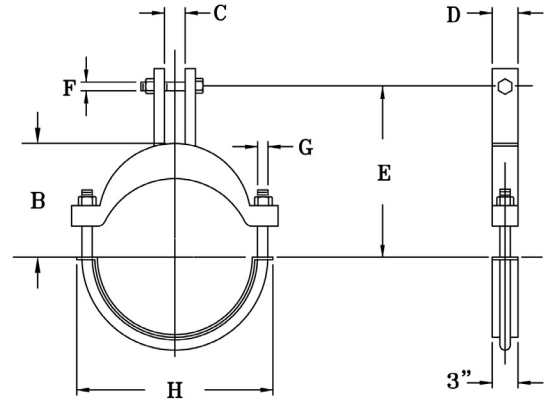

**FIG. 42 - STANDARD** [www.pipingtech.com/fig42](http://www.pipingtech.com/fig42)

PIPE SIZE	MAX. RECOM. LOAD (lb.)			B	C	D	E	F	G	H	APPROX. WEIGHT (lb. per 100)
	@ 950 °F	@1050 °F	@1100°F								
8 5/8 - 10 13/16	9,500	9,100	8,800	9 1/2	2	4	13 3/4	1 1/2	7/8	14 1/2	4,900
10 7/8 - 12 13/16	9,500	9,100	8,800	10 1/2	2	4	14 3/4	1 1/2	7/8	16 1/2	5,400
12 7/8 - 14 1/8	9,500	9,100	8,800	11 1/4	2	4	15 1/2	1 1/2	7/8	18	5,900
14 3/16 - 16 1/8	12,500	12,000	11,500	13	2 1/4	5	16 3/4	1 3/4	1	21	10,400
16 3/16 - 18 1/8	12,500	12,000	11,500	14	2 1/4	5	17 3/4	1 3/4	1	23	11,300
18 3/16 - 20 1/4	12,500	12,000	11,500	15	2 1/4	5	18 3/4	1 3/4	1	25	12,500
20 5/16 - 22 1/4	15,500	15,000	14,500	16 1/2	2 1/4	5	20	2	1 1/8	28	16,200
22 5/16 - 24 1/4	15,500	15,000	14,500	17 1/2	2 1/4	5	21	2	1 1/8	30	17,600
24 5/16 - 26 1/4	15,500	15,000	14,500	18 1/2	2 1/4	5	22	2	1 1/8	32	19,300
26 5/16 - 28 1/4	20,000	19,200	18,500	20	2 1/2	6	23 3/4	2 1/4	1 1/4	34 1/2	27,400
28 5/16 - 30 1/4	20,000	19,200	18,500	21	2 1/2	6	24 3/4	2 1/4	1 1/4	36 1/2	29,800

SCOMPONENTS02.XLS-07/01/09

**FIG. 43 - HEAVY DUTY** [www.pipingtech.com/fig43](http://www.pipingtech.com/fig43)

PIPE SIZE	MAX. RECOM. LOAD (lb.)			B	C	D	E	F	G	H	APPROX. WEIGHT (lb. per 100)
	@ 950 °F	@1050 °F	@1100°F								
8 5/8 - 10 13/16	13,500	12,000	11,500	10 1/4	2 1/4	5	14	1 3/4	1	15 1/4	7,200
10 7/8 - 12 13/16	16,500	15,000	14,500	11 3/4	2 1/4	5	15 1/4	2	1 1/8	17 3/4	10,300
12 7/8 - 14 1/8	16,500	15,000	14,500	12 1/2	2 1/4	5	16	2	1 1/8	19 1/4	11,000
14 3/16 - 16 1/8	20,000	19,200	18,500	13 3/4	2 1/2	6	17 1/2	2 1/4	1 1/4	22	16,700
16 3/16 - 18 1/8	20,000	19,200	18,500	14 3/4	2 1/2	6	18 1/2	2 1/4	1 1/4	24	18,000
18 3/16 - 20 1/4	23,700	22,700	21,900	16	2 3/4	6 1/2	20	2 1/2	1 3/8	26 1/2	22,800
20 5/16 - 22 1/4	23,700	22,700	21,900	17	2 3/4	6 1/2	21	2 1/2	1 3/8	28 1/2	24,600
22 5/16 - 24 1/4	29,000	28,000	27,000	18 1/2	3	7	22 3/4	2 3/4	1 1/2	30 3/4	32,500
24 5/16 - 26 1/4	29,000	28,000	27,000	19 1/2	3	7	23 3/4	2 3/4	1 1/2	32 3/4	34,000
26 5/16 - 28 1/4	29,000	28,000	27,000	20 1/2	3	7	24 3/4	2 3/4	1 1/2	34 3/4	35,500
28 5/16 - 30 1/4	29,000	28,000	27,000	21 1/2	3	7	25 3/4	2 3/4	1 1/2	36 3/4	36,900
36	29,000	28,000	27,000	24 1/2	3	7	28 1/2	2 3/4	1 1/2	43 1/4	42,000

SCOMPONENTS02.XLS-09/17/09