

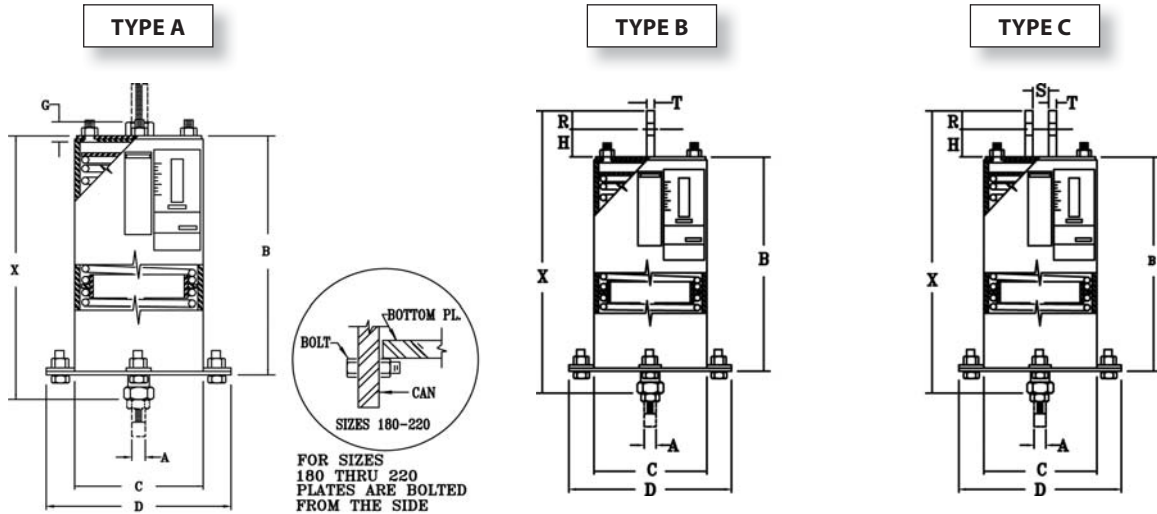

## FIG. PTP-4

## DOUBLE VARIABLE SPRINGS

[www.pipingtech.com/ptp4-abc](http://www.pipingtech.com/ptp4-abc)



**ORDERING:** Specify figure number, size, type, description, operating load and calculated amount and direction of pipe movement from installed to operating position. Please specify any non-standard requirements, i.e. internally guided load column, jacking bolt, lifting lugs, etc.

GENERAL DIMENSIONS FOR FIG. PTP-4				TYPE A			TYPES B & C								TYPES A, B & C
HANGER SIZE	ROD SIZE	CASING DIA.	BOTT. PLATE DIA.	CASING LENGTH	LOADED LENGTH X		CASING LENGTH	LUG HOLE SIZE	HEIGHT OF PIN	R	CLEVIS OPENING	THICKNESS	LOADED LENGTH X		APPROX. WEIGHT OF EACH
	A	C	D		B	MIN.							MAX.	B	
00	1/2	4	6 1/8	13 1/2	14 3/8	19 3/8	13 1/2	11/16	1 1/2	1 1/4	7/8	1/4	17 1/8	22 1/8	11
10	1/2	4	6 1/8	15 1/4	15 15/16	20 15/16	15 1/4	11/16	1 1/2	1 1/4	7/8	1/4	18 11/16	23 11/16	13
20	1/2	4	6 1/8	16 3/4	17 7/16	22 7/16	16 3/4	11/16	1 1/2	1 1/4	7/8	1/4	20 3/16	25 3/16	15
30	1/2	5 9/16	7 5/8	14 7/8	15 3/4	20 3/4	14 7/8	11/16	1 1/2	1 1/4	7/8	1/4	18 1/2	23 1/2	20
40	1/2	5 9/16	7 5/8	16	16 1/16	21 1/16	16	11/16	1 1/2	1 1/4	7/8	1/4	18 13/16	23 13/16	23
50	1/2	5 9/16	7 5/8	17 1/2	18 7/16	23 7/16	17 1/2	11/16	1 1/2	1 1/4	7/8	1/4	21 3/16	26 3/16	25
60	5/8	6 5/8	8 7/8	17 1/4	18 3/8	23 3/8	17 1/4	13/16	1 1/2	1 1/4	1 1/16	1/4	26 1/8	26 1/8	38
70	5/8	6 5/8	8 7/8	19 1/8	20 3/8	25 3/8	19 1/8	13/16	1 1/2	1 1/4	1 1/16	1/4	28 1/8	28 1/8	46
80	5/8	6 5/8	8 7/8	20 1/8	21 3/8	26 3/8	20 1/8	13/16	1 1/2	1 1/4	1 1/16	1/4	29 1/8	29 1/8	58
90	3/4	8 5/8	11 5/8	20 1/16	20 7/8	25 7/8	20 1/16	15/16	1 1/2	1 1/4	1 1/4	3/8	23 5/8	28 5/8	87
100	3/4	8 5/8	11 5/8	22 7/16	23 5/16	28 5/16	22 7/16	15/16	1 1/2	1 1/4	1 1/4	3/8	26 1/16	31 1/16	104
110	3/4	8 5/8	11 5/8	18 1/16	19 11/16	24 11/16	18 1/16	15/16	1 1/2	1 1/4	1 1/4	3/8	22 7/16	27 7/16	88
120	1	8 5/8	11 5/8	19 5/8	21 9/16	26 9/16	19 5/8	1 1/4	2	1 1/2	1 5/8	1/2	25 1/16	30 1/16	98
130	1	8 5/8	11 5/8	24 5/8	25 7/8	30 7/8	24 5/8	1 1/4	2	1 1/2	1 5/8	1/2	29 3/8	34 3/8	134
140	1 1/4	8 5/8	11 5/8	25 3/8	26 7/8	31 7/8	25 3/8	1 1/2	3	2	2	5/8	31 7/8	36 7/8	143
150	1 1/4	8 5/8	11 5/8	25 3/8	28 1/4	33 1/4	25 3/8	1 1/2	3	2	2	5/8	33 1/4	38 1/4	158
160	1 1/2	8 5/8	11 5/8	30	33 1/16	38 1/16	30	1 3/4	3	2 1/2	2 3/8	3/4	38 9/16	43 9/16	204
170	1 3/4	8 5/8	11 5/8	34 1/4	38 3/16	43 3/16	34 1/4	2	3	2 1/2	2 3/8	3/4	43 11/16	48 11/16	259
180	2	12 3/4	N/A	35 1/2	37 5/8	42 5/8	35 1/2	2 3/8	4	3	2 7/8	3/4	44 5/8	49 5/8	482
190	2 1/4	12 3/4	N/A	40	42 3/8	47 3/8	40	2 5/8	4 1/2	3	3 1/8	3/4	49 7/8	54 7/8	570
200	2 1/2	12 3/4	N/A	48 3/8	50 3/4	55 3/4	48 3/8	2 7/8	4 1/2	4	3 1/4	1	59 1/4	64 1/4	772
210	2 3/4	12 3/4	N/A	53	55 5/8	60 5/8	53	3 1/8	4 1/2	4	3 5/8	1	64 1/8	69 1/8	910
220	3	12 3/4	N/A	65 1/8	68	73	65 1/8	3 3/8	5	4	3 7/8	1	77	82	1210

SPRING.XLS-06/07/19