



FIG. 800

U-BOLT CRADLE SUPPORT WITH GUIDE & SLIDE PLATE CRADLED GUIDED SUPPORT

www.pipingtech.com/fig800

- MATERIAL:** Carbon steel
- FINISH:** Painted or hot dipped galvanized.
- OPTIONS:** Modifications in the dimensions A, B, C, D, and the slide plate material (PTFE, 25% glass filled or graphite) available upon request.
- ORDERING:** Specify figure number, pipe size, description, type, quantity, finish and slide plate material.
- ALLOWABLE LOADS:** The allowable vertical loads depend upon the pipe pressure and wall thickness.
- BONDING:** Graphite slide plates are usually bonded. For high temperature service above 500 °F specify bolted construction.
- NOTE:**
- Optional bolted base plate, specify Fig. 801.
 - For upper graphite slide material to be of bolted design, specify Fig. 800 base plate or Fig. 801 base plate (see below).



FIG. 800 - WELDED BASE



FIG. 801 - BOLTED BASE

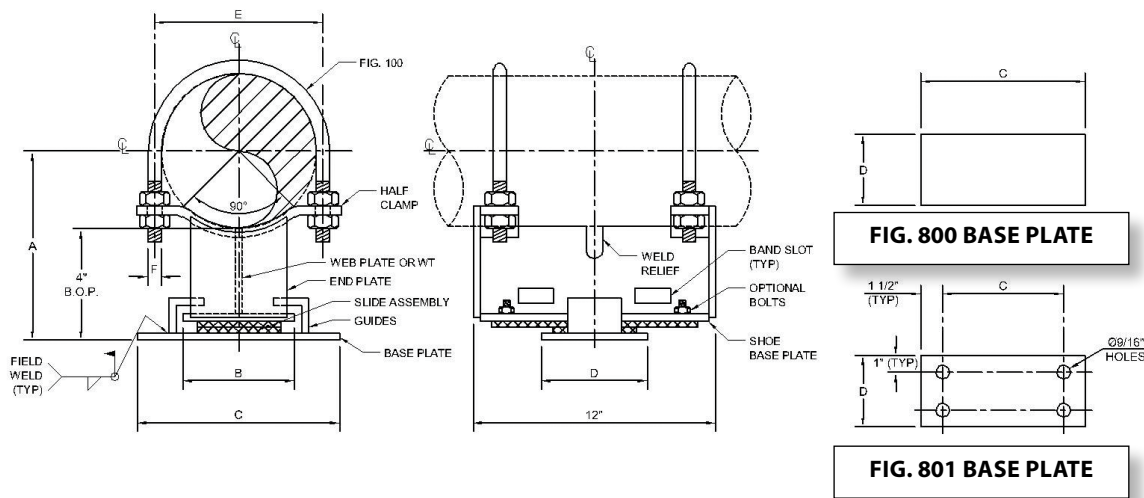

PIPE SIZE	A	B	C	D	E	F	APPROX. WEIGHT (lb. per each)
2	5 3/16	4	7 1/4	5	2 7/8	3/8	17.0
3	5 3/4	4	7 1/4	5	4 1/8	1/2	19.0
4	6 1/4	4	7 1/4	5	5 1/8	1/2	21.0
6	7 5/16	4	7 1/4	5	7 3/8	5/8	24.0
8	8 5/16	4	7 1/4	5	9 3/8	5/8	26.0
10	9 3/8	4	7 1/4	5	11 5/8	3/4	33.0
12	10 3/8	4	7 1/4	5 1/2	13 3/4	7/8	41.0
14	11	4	7 1/4	5 1/2	15	7/8	48.0
16	12	4	7 1/4	5 1/2	17	7/8	51.0
18	13	7	10 3/4	5 1/2	19 1/8	1	72.0
20	14	7	10 3/4	5 1/2	21 1/8	1	76.0
24	16	7	11 1/4	5 1/2	25 1/8	1	86.0

PIPESH0ES01.XLS-09/19/09